

Applied Optoelectronics in Medicine

Aplikovaná optoelektronika v lékařství

Interdisciplinary course at the CTU Prague (P317APL-E, W, 4 credits)

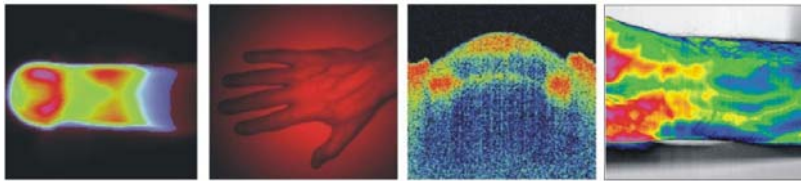

4. Reflection, transmission and scattering behaviour of biotissue 4. Reflektivní, transmitivní a rozptylové vlastnosti tkáně

© V. Blazek, MedIT, 2017
All rights reserved
Lecture 4, Page 1

Applied Optoelectronics in Medicine

RWTHAACHEN
UNIVERSITY

Learning aims of the fourth AOM lecture

- Spectral skin reflection and scattering behaviour
- Integrated sphere sensor („Ulbricht-Kugel“)
- Spectroscopy measuring set-up
- Tissue color analysis

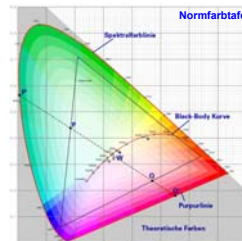
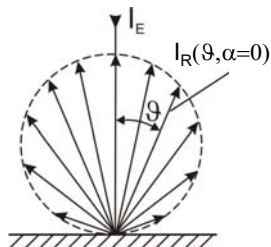

© V. Blazek, MedIT, 2017
All rights reserved
Lecture 4, Page 2

Applied Optoelectronics in Medicine

RWTHAACHEN
UNIVERSITY

Biological interactions light - matter

Depending on:

- Energy and power density
- Wavelength
- Exposure time
- Properties of the tissue (Tissue type, pigmentation, blood perfusion, superficial texture / hair ...)

•Effect (impairment) mechanisms:

- Non-destructive interaction
- Photochemical effect
- Thermal influence
- Thermo-acoustic effect
- Irreversible tissue changes
- Late consequences

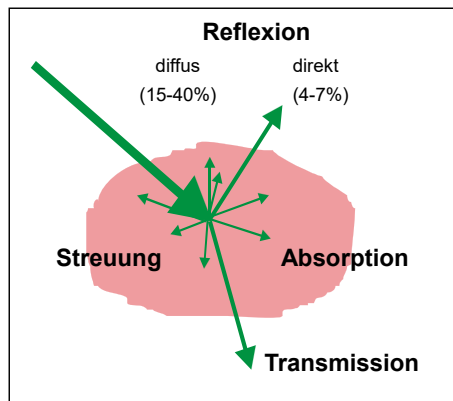

Reflection of biotissue, basics of color description

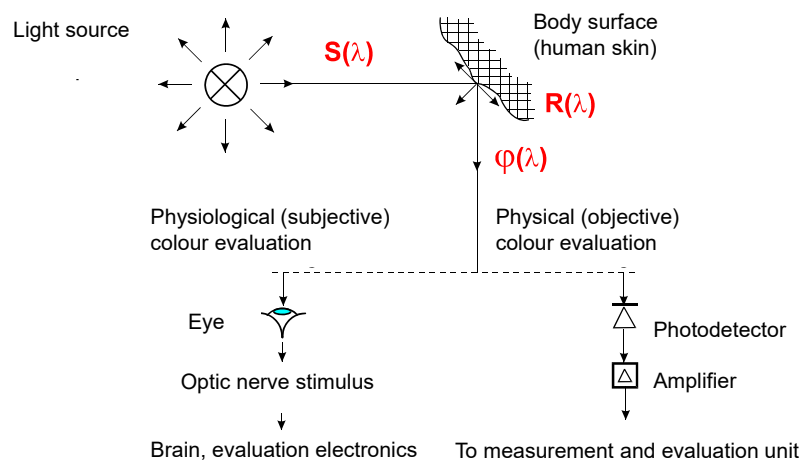

Terms and parameters of tissue optics

For the optical characterisation of the skin and other biological probes mainly the parameter reflection, transmission und extinction are used:

$$R(\lambda) = \frac{\Phi_R}{\Phi_E}, \quad T(\lambda) = \frac{\Phi_T}{\Phi_E}, \quad \Gamma(\lambda) = \frac{\Phi_I}{\Phi_E},$$

$$R(\lambda) + T(\lambda) + \Gamma(\lambda) = 1$$

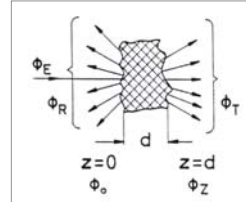

Under the assumption of linear extinction the law of Lambert is valid:

$$\Phi_z = \Phi_0 e^{-\mu_t(\lambda)z} \quad \text{and after using of } \Phi_0 \text{ and } \Phi_z: \quad \frac{\Phi_E - \Phi_R - \Phi_T}{\Phi_E - \Phi_R} = e^{-\mu_t(\lambda)d}$$

Spectral extinction, absorption and scattering coefficient:

$$\mu_t = \mu_a + \mu_s = -\frac{\ln \frac{1 - R(\lambda) - \Gamma(\lambda)}{1 - R(\lambda)}}{d}$$

Reflection mechanisms of optical radiation on biological tissue

On these entirely inhomogeneous, anisotropic and lossy samples such as the human skin, various types of reflection occur:

Types of reflections:

- Regular reflection
- diffuse with partial mirroring
- ideal diffuse

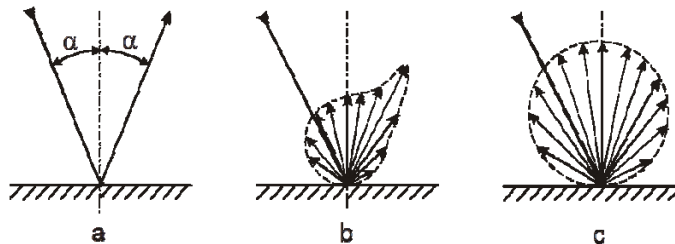

Remember:

The limiting cases (a,c) allow easy data collection, processing and analytical description, but they are only an approximation of what happens in reality.

Regular reflection / transmission on an optical interface

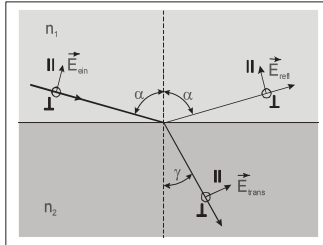

Reflection und Transmission of a Light-beam at a boundary layer (surface interface) of two lossless and non-magnetic media with refractive indices n_1 and n_2 . For $\alpha=0^\circ$ ist the Fresnel equation:
(A. J. FRESNEL (1788 – 1827))

$$|r| = \frac{|\vec{E}_{refl}(z)|}{|\vec{E}_{ein}(z)|} \quad \text{and} \quad |t| = \frac{|\vec{E}_{trans}(z)|}{|\vec{E}_{ein}(z)|}$$

Considering boundary conditions at the interface, the reflection coefficient is:

$$r = \frac{\frac{1}{n_2} - \frac{1}{n_1}}{\frac{1}{n_2} + \frac{1}{n_1}} = \frac{n_1 - n_2}{n_1 + n_2}$$

and the Transmission coefficient:

$$t = \frac{2n_1}{n_1 + n_2}$$

Regular reflection / transmission on an optical interface

For an obliquely incident light beam (α not equal to 0°) the law of Willebrord Snell van Royen (1620) provides the relationship between the refractive indices and the angles α and β :

$$n_1 \cdot \sin(\alpha) = n_2 \cdot \sin(\beta) = NA$$

Remember: The product of refractive index and the sine of the angle of refraction is immutable and is called - according to Ernst Abbe (1873) - the numerical aperture of the beam against the normal line.



Willebrord van Roijen **Snell**
(1580 – 1626)



Augustin Jean **Fresnel**
(1788 – 1827)



Ernst Karl **Abbe**
(1840 – 1905)

Regular reflection / transmission on an optical interface

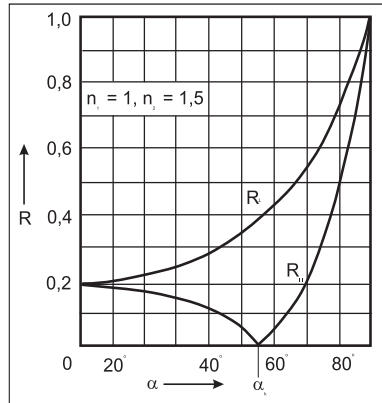

Dependence of the reflection coefficient of perpendicular (I) and parallel (II) plane polarized light on the angle of incidence.

For a natural radiation, that may be used for skin reflection screening, is:

$$R_{reg} = \frac{1}{2} \left[\frac{\sin^2(\alpha - \beta)}{\sin^2(\alpha + \beta)} - \frac{\text{tg}^2(\alpha - \beta)}{\text{tg}^2(\alpha + \beta)} \right]$$

Critical angle (Totalreflection) at the boundary between optically dense to an optically thin medium :

$$\alpha_c = \text{arc sin } \frac{n_2}{n_1}$$

Remember:

Regular reflection depends on the light polarisation

Regular (simple) reflection / transmission on an optical interface: light incidence from the optically thinner medium

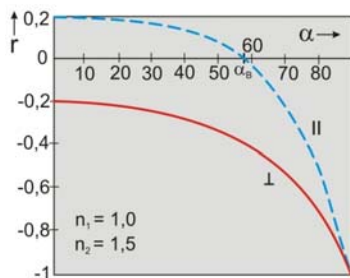

Remember:

r ... Reflection coefficient
 $R = r^2$... Reflectivity, reflectance

Often also the following graphical representation (for $r = f(\alpha)$) is used:

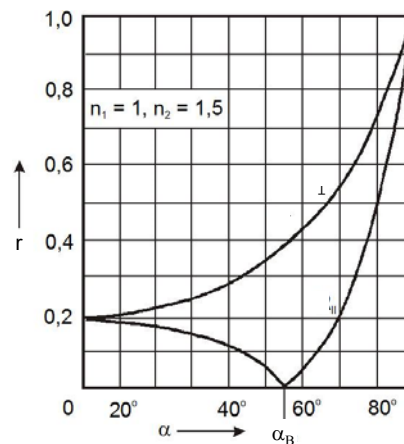

Regular (simple) reflection / transmission on an optical interface: light incidence from the optically denser medium

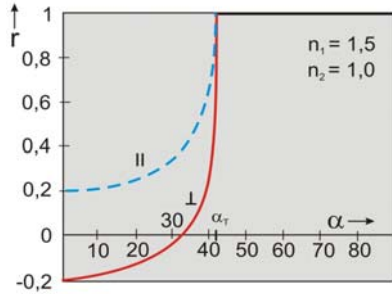

Dependence of the reflection coefficient for perpendicular (\perp) and parallel (\parallel) to the incident plane polarized light from the angle of incidence α .

For the case of radiation from an optically denser medium, the refraction law provides the critical angle of total reflection α_T (first observed by J. Keppler in 1611):

$$\alpha_T = \arcsin \frac{n_2}{n_1}$$

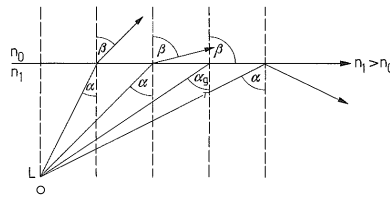

Remember:

For all angles of incidence $\alpha > \alpha_T$ occurs no transmitted beam and the reflection coefficient is equal for both polarization directions ($r = r_{\parallel} = 1$).

Special case: Ideal diffuse reflection of an (ideal opaque) surface (also called Lambertian reflection or remission)

In the theory of J. H. LAMBERT (1728 – 1777) an irradiated, perfect opaque surface is seen as a Planar radiator with a radiant intensity I_R :

$$I_R = L_a \cos \vartheta \quad ; \quad L = \frac{R}{a} I_E \cos \alpha$$

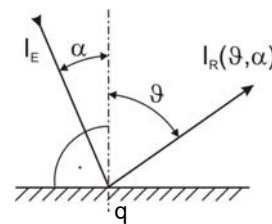

R is the reflectance of the surface q . At an ideal diffuse reflector, totally opaque white (non-absorbing) surface (Lambertian emitter) is $R = 1$. For I_R an L the angular distribution follows:

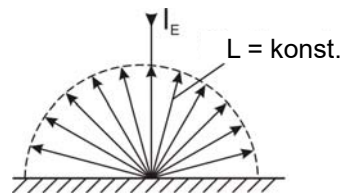
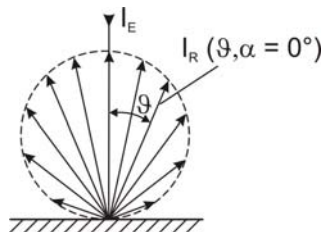

Diffuse Reflexion einer (fast) matten, realen Oberfläche

Wird nicht der gesamte eingestrahle Strahlungsfluss Φ_E von einem (realen) Medium reflektiert ($R < 1$), gehorcht aber die rückgestreute Strahlstärke I_R dennoch dem Kosinus-Gesetz (z. B. MgO- oder BaSO₄-Pulver), so wird das Reflexionsvermögen dieser Fläche auch ideal diffus genannt.

Bei solchen Medien kann die gesamte Reflexion analytisch bestimmt werden; es braucht nur die Reflektierte Strahlstärke unter einem beliebig wählbaren Winkel gemessen werden:

$$R_{(ideal\ diff.)} = \left(\frac{\Phi_R(\vartheta_1)}{\Phi_E \cdot \cos \alpha \cdot \Omega_1 \cdot \cos \vartheta_1} \right) \cdot \int_{\vartheta_1}^{\pi/2} \int_{\varphi=0}^{2\pi} \cos \vartheta \cdot \sin \vartheta \cdot d\vartheta \cdot d\varphi$$

Da das rechts stehende Integral den Wert π ergibt, gilt bei senkrechter Einstrahlung:

$$R_{(ideal\ diff., \alpha=0^\circ)} = \frac{\Phi_R(\vartheta_1)}{\Phi_E} \cdot \frac{\pi}{\Omega_1 \cdot \cos \vartheta_1}$$

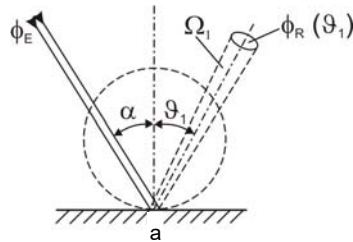

Geometrische Bedingungen bei Reflexionsmessung biologischer Proben

nach DIN 5031, Teil 1-7 (Strahlungsphysik im optischen Bereich und Lichttechnik) und DIN 5033, Teil 1-9 (Farbmessung)

- 2) Die d / 8° - Kugel-Messgeometrie** **3) Die 8° / d – Kugel-Messgeometrie**

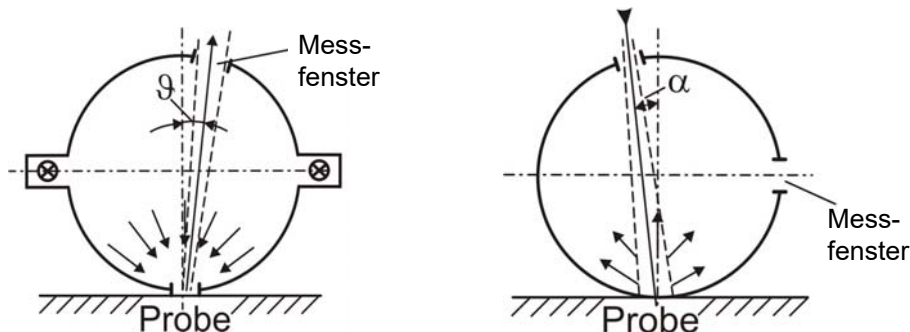

Strahlungsintegrierender Sensor (Ulbricht-Kugel, auch Photometerkugel genannt) zur Erfassung der diffusen Reflexion (Remission) biologischer Proben



The first theory describing the integrating sphere was published in 1892 by W. E. Sumpner. The German physicist, R. Ulbricht, developed the first working integrating sphere in 1894.

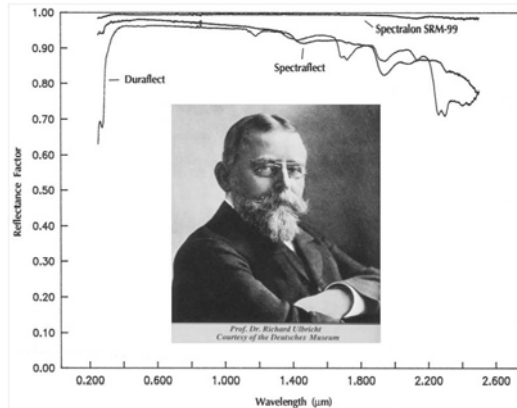

Integrating sphere: Diffuse reflectance materials and coatings for the UV-, VIS and NIR

Amplification factor ρ' of the Ulbricht sphere

Voraussetzungen:

- der Hohlraum ist kugelförmig;
- in der Photometerkugel sind keine absorbierende Teile;
- die Innenwand reflektiert ideal diffus.

Ortsunabhängige Bestrahlungsstärke an der Innenwand der Kugel ist abhängig vom Reflexionsfaktor ρ der Kugelbeschichtung resp. von dem Verstärkungsfaktor ρ' :

$$I_{HK} = \frac{\Phi_E \cdot \rho_\lambda}{q \cdot (1 - \rho_\lambda)} = \frac{\Phi_E}{q} \cdot \rho'_\lambda$$

$$q = 4 \cdot \pi \cdot r_{HK}^2 \quad \dots \text{Gesamtfläche der Kugelinne wand}$$

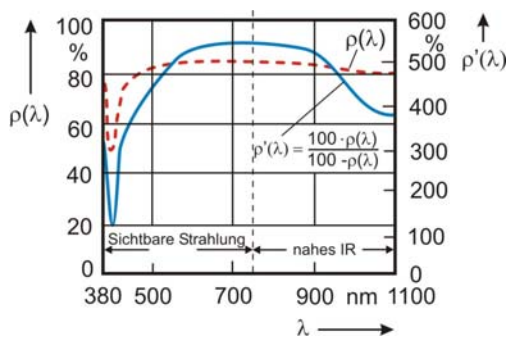
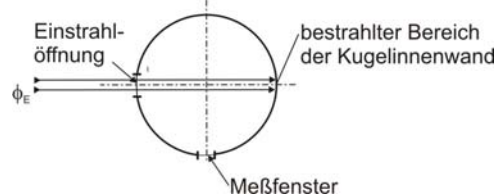

Ulbricht sphere version
for the optical two-beam measurement principle

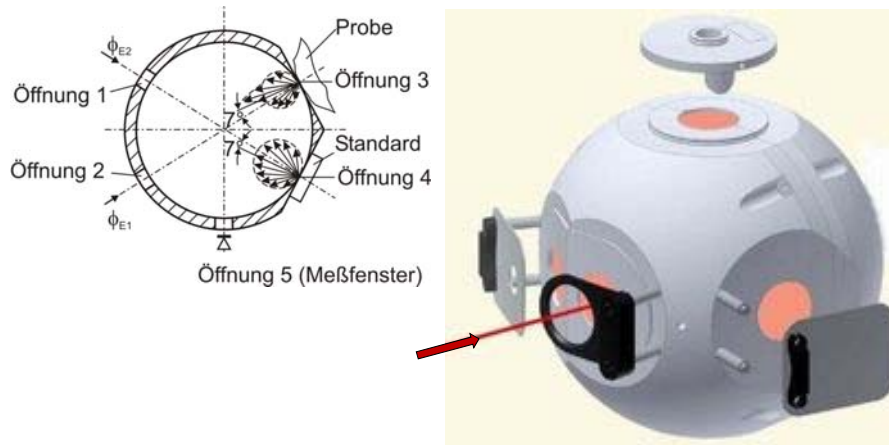

Modell UPB-150-ART von Gigahertz-Optics Inc., Newburyport, MA, USA

© V. Blazek, MedIT, 2017
All rights reserved
Lecture 4, Page 17

Applied Optoelectronics in Medicine

RWTHAACHEN
UNIVERSITY



Spektralphotometer 554 with
movable Ulbricht sphere

Company: Firma Perkin-Elmer, Überlingen, Bodensee
(190 – 900 nm, $\Delta\lambda < 0,5 - 4 \text{ nm}>$)

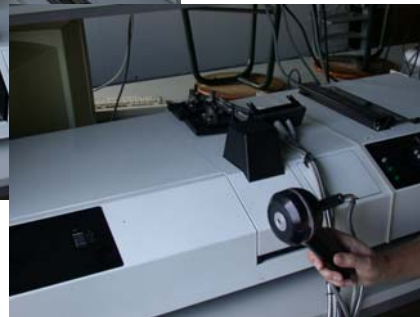

© V. Blazek, MedIT, 2017
All rights reserved
Lecture 4, Page 18

Applied Optoelectronics in Medicine

RWTHAACHEN
UNIVERSITY

Typical reflexion spectra of a fresh picked plant leaf

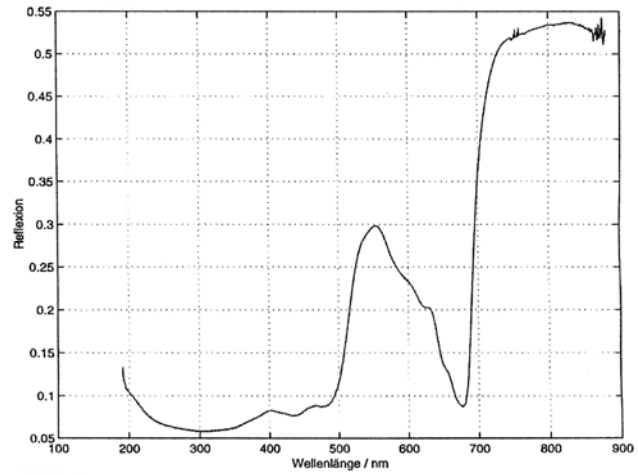

© V. Blazek, MedIT, 2017
All rights reserved
Lecture 4, Page 19

Applied Optoelectronics in Medicine

RWTHAACHEN
UNIVERSITY

Typical transmission spectra of a transparent red foil

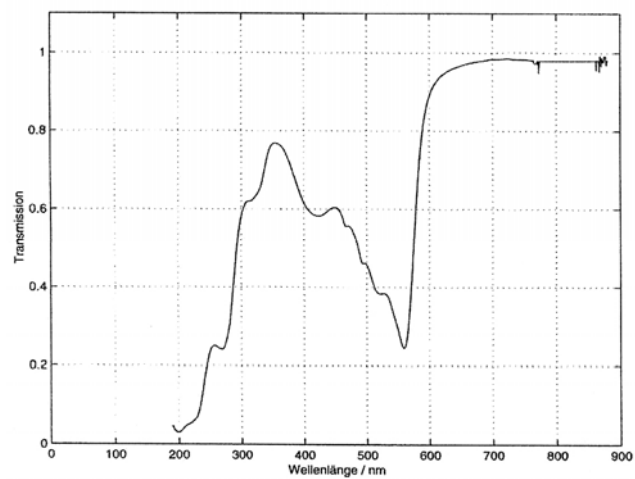

© V. Blazek, MedIT, 2017
All rights reserved
Lecture 4, Page 20

Applied Optoelectronics in Medicine

RWTHAACHEN
UNIVERSITY

In vivo reflection spektroskopie:

The connection of the Ulbricht sphere and the spectrophotometer is done via two flexible fiber optic bundle



Spektralphotometer 554 der Firma Perkin-Elmer, Überlingen, Bodensee (190 – 900 nm, $\Delta\lambda < 0,5 - 4 \text{ nm}$)

Experimental setup for in vivo reflection spektroskopie

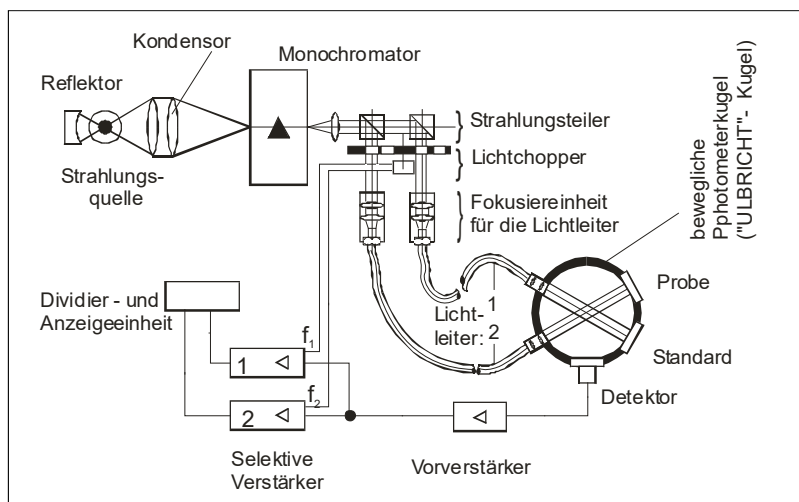

Blazek, V.: Ein optoelektronisches Meßverfahren zur farbvalenzmetrischen Bewertung der menschlichen Haut, Dissertation, RWTH Aachen 1979

Typical reflection spectra of human skin in vivo

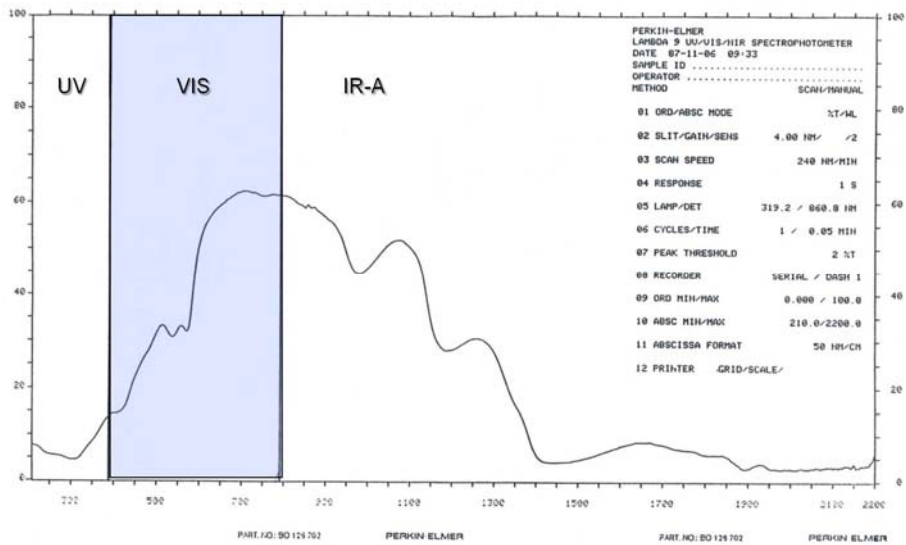

© V. Blazek, MedIT, 2017
 All rights reserved
 Lecture 4, Page 23

Applied Optoelectronics in Medicine

RWTH AACHEN
 UNIVERSITY

Wavelength dependence of human skin reflection coefficient and transmission coefficient of oxygenated blood, diluted with water (1:200)

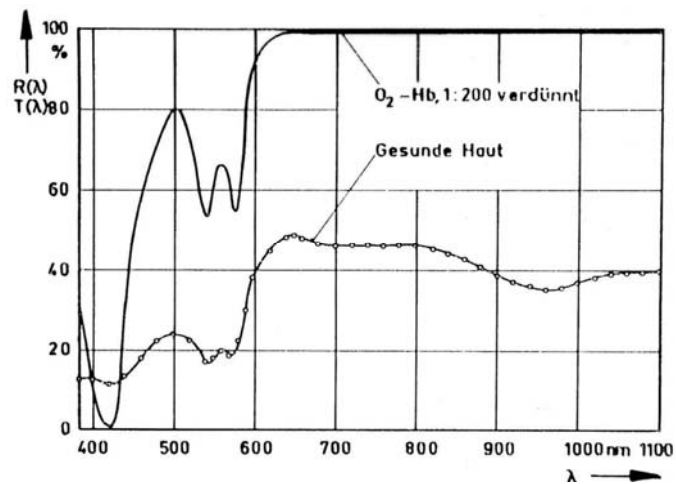

© V. Blazek, MedIT, 2017
 All rights reserved
 Lecture 4, Page 24

Applied Optoelectronics in Medicine

RWTH AACHEN
 UNIVERSITY

Reflection, transmission and extinction of human epidermis ($d = 0.3 \text{ mm}$), 3 hours after excision

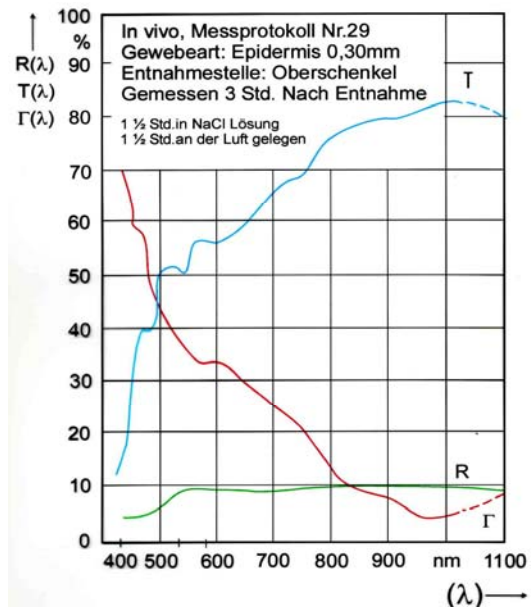

Epidermis spectra from: Blazek, V.: Reflexionsspektroskopie der Haut, PhD thesis, RWTH Aachen 1979

© V. Blazek, MedIT, 2017
 All rights reserved
 Lecture 4, Page 25

Applied Optoelectronics in Medicine



Application of reflection spectroscopy in neonatology

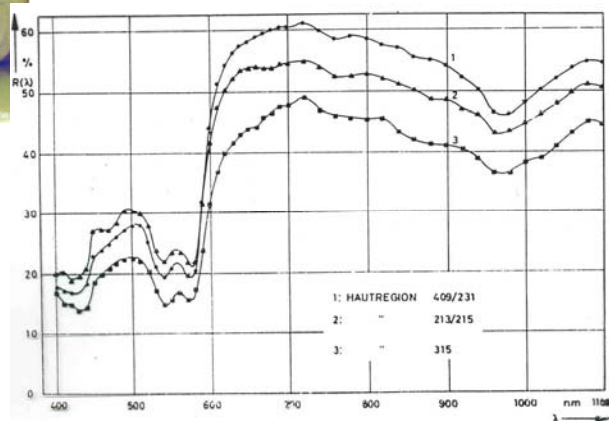

© V. Blazek, MedIT, 2017
 All rights reserved
 Lecture 4, Page 26

Applied Optoelectronics in Medicine



Application of reflection spectroscopy in forensic medicine

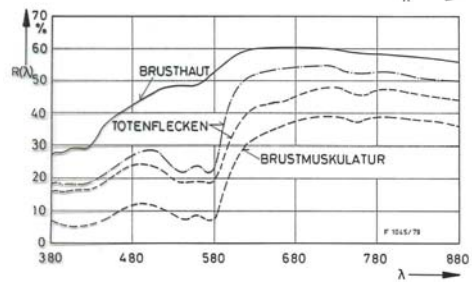
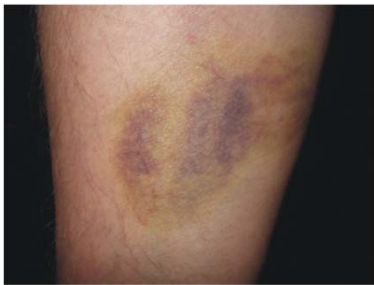
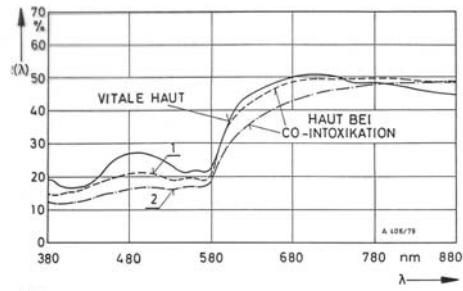

© V. Blazek, MedIT, 2017
All rights reserved
Lecture 4, Page 27

Applied Optoelectronics in Medicine

RWTHAACHEN
UNIVERSITY

Application of reflection spectroscopy in forensic medicine

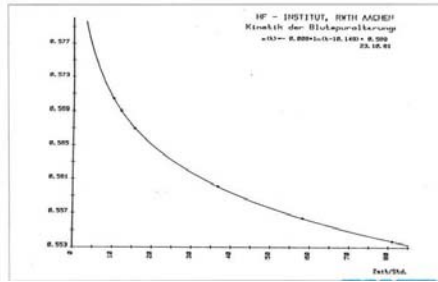
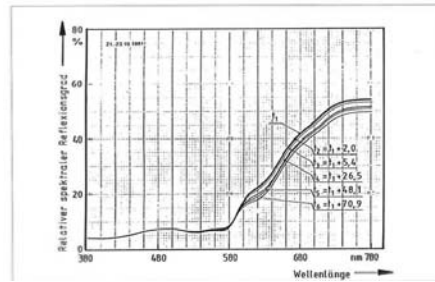
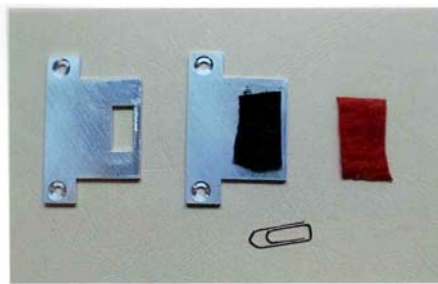
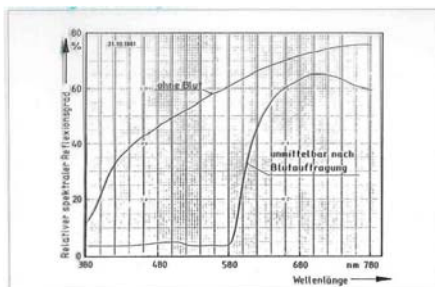

© V. Blazek, MedIT, 2017
All rights reserved
Lecture 4, Page 28

Applied Optoelectronics in Medicine

RWTHAACHEN
UNIVERSITY

Reflection spektroskopy and color analytics in food industry



Example: the color of fresh fruit (left) and meat (right)

Color of meat is primary depended from the amount of myoglobin, the ratio of different myoglobin forms (reduced myoglobin, oxymyoglobin, metmyoglobin), the reflection at the tissue surface (e.g. by water) and the pH value of the meat.

© V. Blazek, MedIT, 2017
All rights reserved
Lecture 4, Page 29

Applied Optoelectronics in Medicine

RWTHAACHEN
UNIVERSITY

Reflection spektroskopy as a basis for color analysis in the textile and cosmetic industry



© V. Blazek, MedIT, 2017
All rights reserved
Lecture 4, Page 30

Applied Optoelectronics in Medicine

RWTHAACHEN
UNIVERSITY

Reflection spectroscopy for quality control of colored surfaces

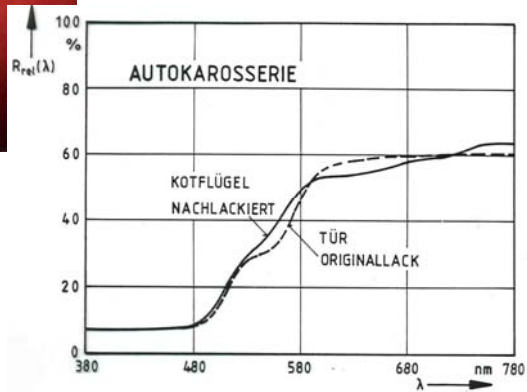
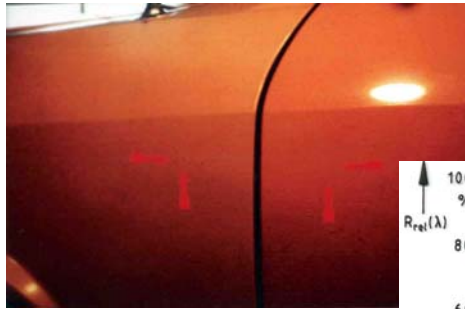

© V. Blazek, MedIT, 2017
All rights reserved
Lecture 4, Page 31

Applied Optoelectronics in Medicine

RWTHAACHEN
UNIVERSITY

Reflection spectroscopy in the identification of fakes

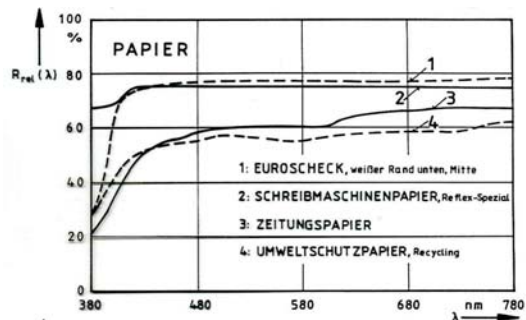
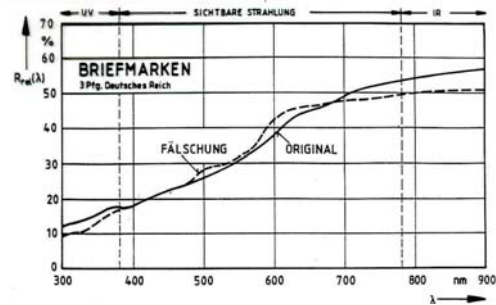

© V. Blazek, MedIT, 2017
All rights reserved
Lecture 4, Page 32

Applied Optoelectronics in Medicine

RWTHAACHEN
UNIVERSITY

Application of reflection spectroscopy on determination of color stimulus specification, basics of colorimetry

Colorimetry comprises development of measuring systems, numerical evaluation and quantitative determination of human colour perception.

If the spectral reflection coefficient $R(\lambda)$ of biotissue is known, We can determine for any illumination spectra ($S(\lambda)$) the color assessment.

Spectral color distribution:
$$\varphi(\lambda) = S(\lambda) \cdot R(\lambda)$$

- On the right:
 Relative spectral radiant distribution of norm light types.
 A) Average light bulb (glow-lamp), 2856 °K
 B) Daylight without UV light
 D65) Simulation of daylight with „black body radiator“ at 6500 °K

The basic rule of colorimetry says, that any color impression can be completely described by three variables. The color sensitivity of a „norm-observer 1933“ as „standardized observer color matching functions“ $x(\lambda)$, $y(\lambda)$ and $z(\lambda)$.

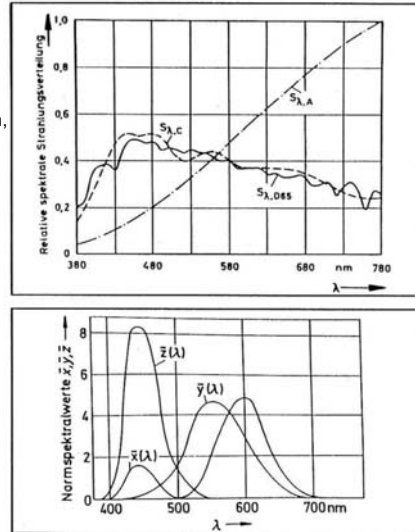

The color matching functions

are the numerical description of the chromatic response of the observer. The tristimulus values for a color with a spectral power distribution are given in terms of the standard observer by:

$$X = k \int_{380nm}^{780nm} \varphi(\lambda) \cdot \bar{x}(\lambda) \cdot d\lambda$$

$$Y = k \int_{380nm}^{780nm} \varphi(\lambda) \cdot \bar{y}(\lambda) \cdot d\lambda$$

$$Z = k \int_{380nm}^{780nm} \varphi(\lambda) \cdot \bar{z}(\lambda) \cdot d\lambda$$

A full plot of all visible colors is a three-dimensional figure. However, the concept of color description can be divided into two parts: brightness and chromaticity.

$$x = \frac{X}{X+Y+Z}$$

$$y = \frac{Y}{X+Y+Z}$$

$$z = \frac{Z}{X+Y+Z}$$

The derived color space specified by parameters x , y can be plotted in color space chromaticity diagram (right)

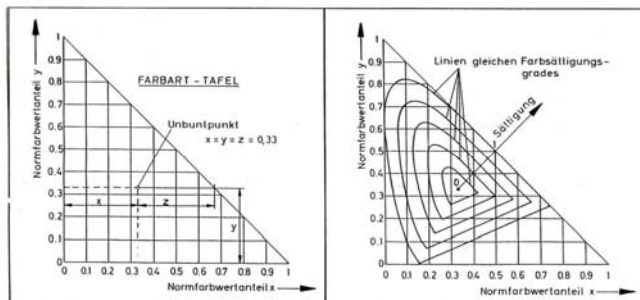

Related chromaticity Diagram (RCD) (german norm DIN 5033)

Chromaticity is an objective specification of the quality of a color regardless of its luminance; that is, as determined by its hue and colorfulness. In the chromaticity diagram, the chromaticity of a color was specified by the two derived parameters x and y , two of the three normalized values which are functions of all three tristimulus values X , Y and Z .

Each point in the chromaticity diagram represents one chromaticity. The colors of the same chromaticity can differ in their brightness.

In the middle of the diagram, the equal energy point E ($x = y = 0.33$) represents ideal white color (achromatic point)

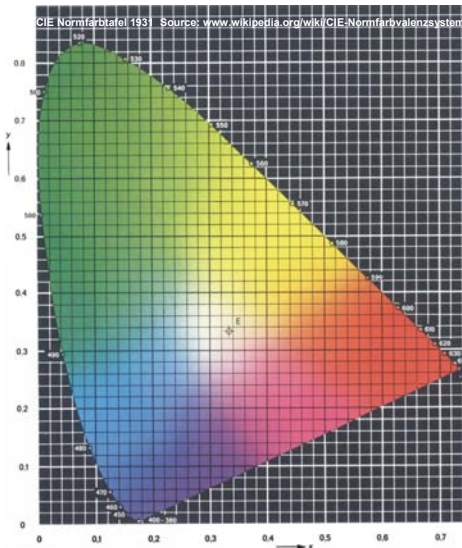

Remember: Related chromaticity diagram is a tool to specify how the human eye will experience light with a given spectrum

Example: normal skin and skin suffering with naevi flammei in RCD

A naevus flammeus (or port-wine stain) is almost always a birthmark. About 3 in 1,000 babies are born with a port-wine stain. Most occur on the face but any area of the skin can be affected. It is caused by a vascular anomaly (a capillary malformation).

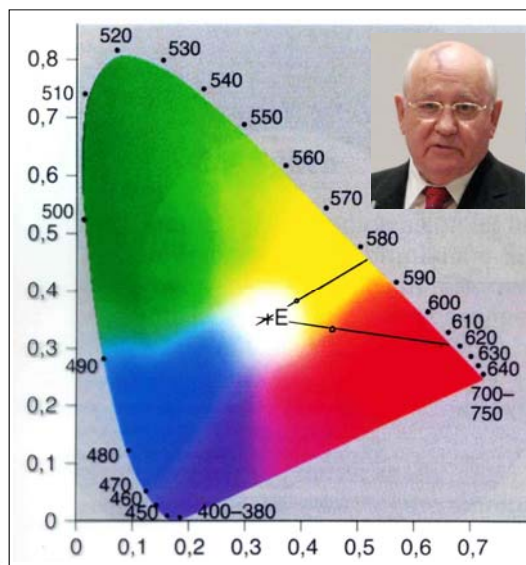
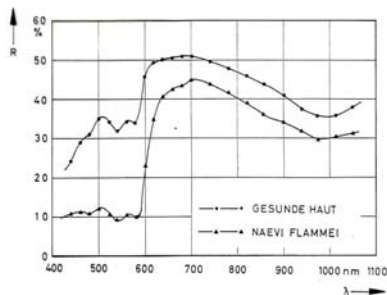

From: Blazek, V.: Reflexionsspektroskopie der Haut. PhD thesis, RWTH Aachen 1979

Principle of additive color mixing using the example of a white LED

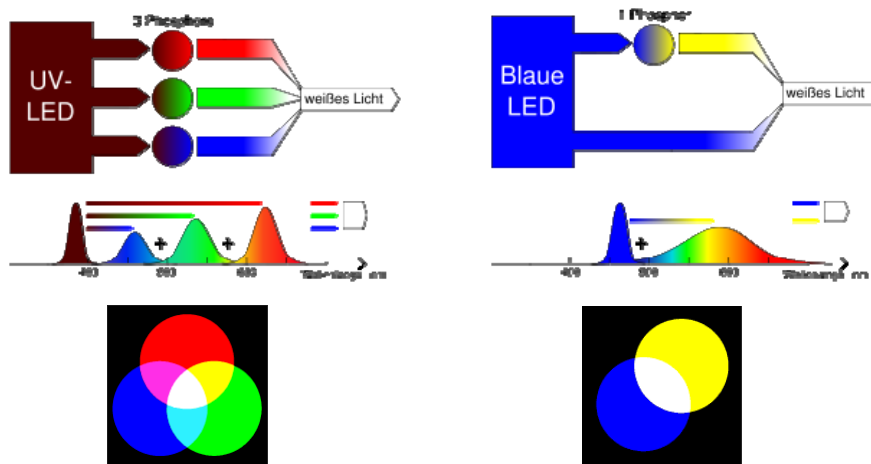

Remember: In the additive color mixing the light is mixed. Red light and green light, for example, yield yellow light.

© V. Blazek, MedIT, 2017
All rights reserved
Lecture 4, Page 37

Applied Optoelectronics in Medicine

RWTHAACHEN
UNIVERSITY

Principle of subtractive color mixing using the example of a color printer

In the subtractive color mixing, the CMY colors of **cyan** (C), **magenta** (M) and **yellow** (Y) are mixed. In practice, the CMYK model is more used. The K stands for **black**. A pure CMY would be in the practice of printing not really deep black, so that black ink is added to it.

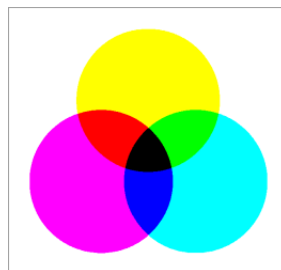

An ink jet printer produces images by throwing small drops of ink onto the paper. The CMYK colors are used and arranged so that the impression can be awakened millions of colors.

Remember: By the subtractive color mixing materials are mixed. Yellow color ink and cyan color ink, for example, yield in a mixture green paint.

© V. Blazek, MedIT, 2017
All rights reserved
Lecture 4, Page 38

Applied Optoelectronics in Medicine

RWTHAACHEN
UNIVERSITY

Citát pro čtvrtou přednášku / Quotation of the lecture 4:

**„Man sieht nur
mit dem Herzen gut:
das Wesentliche ist für
die Augen unsichtbar“**



*Antoine de SAINT-EXUPÉRY (1900 - 1944),
am 31.07.1944 auf Aufklärungsflug verschollen*

© V. Blazek, MedIT, 2017
All rights reserved
Lecture 4, Page 39

Applied Optoelectronics in Medicine

**RWTHAACHEN
UNIVERSITY**

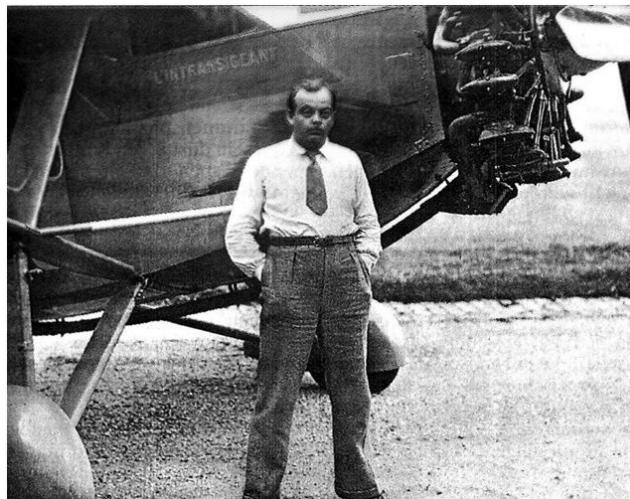

Disappeared in 1944 over the Mediterranean: The photo shows the author and pilot
Antoine de Saint-Exupéry in front of his P-38 Lightning

© V. Blazek, MedIT, 2017
All rights reserved
Lecture 4, Page 40

Applied Optoelectronics in Medicine

**RWTHAACHEN
UNIVERSITY**